

**PRELIMINARY**

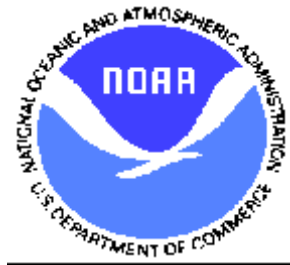

**GOES Data Collection System (DCS)  
System Characterization Report**

**June 3, 1998**

**Mitretek Systems, Inc.**

# **PRELIMINARY**

# ***PRELIMINARY***

## **Executive Summary**

The GOES Data Collection System (DCS) Characterization Report provides an overview of the current state of the GOES Data Collection System. It provides a high level system description, identifies organizational roles and responsibilities, and makes initial recommendations to improve the system. The initial purchase cost of the DCS hardware, software and development effort is estimated at \$7.5 M, and the annual cost to operate and maintain the system is approximately \$1M for personnel and facilities.

The DCS collects and processes mainly environmental data transmitted from international and domestic government-owned Data Collection Platforms (DCP) via transponders located on the GOES East and West spacecraft. The DCS Automatic Processing System (DAPS) stores and distributes the DCP data to primary and secondary users via DOMSAT and the National Weather Service Telecommunications Gateway (NWSTG) from the DCS facility located at the Wallops Command and Data Acquisition Station (WCDAS). Users have access to the platform data and associated database tables via dial-in modems. Internet access and file transfer protocol (FTP) capabilities are being developed at WCDAS to further facilitate user access.

For nearly ten years the DAPS has continued to perform with a very high reliability due to its redundant computer configuration and automatic failover capability. Problematic situations, such as recurrent hard drive failures, have been corrected through interim hardware item replacements. However, periodic system upgrades were not performed as a cost saving measure and, as a consequence, the system is getting seriously out of date. The following concerns were noted and these steps should be taken to correct them:

- C      Year 2000 date problems are known to affect both the Data General AOS/VS operating system and the FORTRAN compiler. A patch to the AOS/VS and further testing is needed to determine the effect on the application code.**
  
- C      No system configuration management is in place to document changes in the DCS hardware and software. Establish and implement a configuration management program.**

The most frequently heard complaint refers to the out-of-date user interface which does not support a windowing system or mouse pointing device. The Data General SQL database management system uses a proprietary format and the corresponding scripting language, PRESENT, is not well understood by users or system managers.

The division of DCS responsibilities between the WCDAS OSO personnel and the OSDPD management staff at Suitland FB-4 is consistent with other NESDIS programs; however, nearly all of the DCS facilities and data distribution functions are located at WCDAS. OSDPD is responsible

# ***PRELIMINARY***

## **Executive Summary**

for managing the DCS and insuring that the data is delivered reliably and accurately to the users, performing user interface functions such as making channel assignments and schedules, negotiating Memoranda of Agreement (MOA) with users, updating Platform Description Tables (PDT), analyzing system performance, generating status reports, etc. During a period when OSDPD DCS management personnel were in transition, WCDAS personnel continued performing the operations and maintenance tasks with minimum contact with OSDPD. Consequently, the close OSO and OSDPD working relationship has been lost and a successful working relationship needs to be reestablished. The following initial steps should be made to improve this relationship:

- C      Generate a Operations/Management Roles and Responsibilities Memorandum of Understanding between OSO and OSDPD.**
  
- C      Conduct regularly scheduled meetings between these organizations to review the DCS status, current problems, and planned enhancements.**

Recommendations to address these and other areas of DC S operations for the near term are included in this interim report. The reports to follow and the final study report will address the longer term solutions of DCS database and system rehost or replacement.

# ***PRELIMINARY***

## **TABLE OF CONTENTS**

	<b>page</b>
<b>Executive Summary</b>	<b>iii</b>
<b>1. Introduction</b>	<b>1</b>
<b>1.1 Document Purpose</b>	<b>1</b>
<b>1.2 Document Scope</b>	<b>1</b>
<b>2. Overview of Current System</b>	<b>1</b>
<b>2.1 Mission</b>	<b>1</b>
<b>2.2 Functional Description and Data Flow</b>	<b>1</b>
<b>2.2.1 Data Collection and Distribution</b>	<b>3</b>
<b>2.2.2 Platform Interrogation</b>	<b>4</b>
<b>2.2.3 DCS Calibration and Self Testing</b>	<b>4</b>
<b>2.3 External Interfaces</b>	<b>5</b>
<b>2.4 DAPS Hardware</b>	<b>9</b>
<b>2.5 DAPS Software</b>	<b>11</b>
<b>2.6 DCS Roles and Responsibilities</b>	<b>13</b>
<b>2.6.1 DCS Management at Suitland</b>	<b>15</b>
<b>2.6.2 DCS Operations at Wallops</b>	<b>17</b>
<b>2.6.3 DCS Users</b>	<b>19</b>
<b>2.7 Errors and Failure Recovery</b>	<b>20</b>
<b>2.8 Configuration Management</b>	<b>20</b>
<b>3. Recommendations</b>	<b>24</b>
<b>Appendix A DCS Cost Summary</b>	<b>28</b>

## **LIST OF FIGURES**

	<b>page</b>
<b>Figure 2-1 Data Collection System Block Diagram</b>	<b>2</b>
<b>Figure 2-2 DCS Automatic Processing System Block Diagram</b>	<b>10</b>
<b>Figure 2-3 NESDIS DCS Organization Chart</b>	<b>14</b>
<b>Figure 2-4 OSDPD DCS Organization Chart</b>	<b>16</b>
<b>Figure 2-5 OSO DCS Organization Chart</b>	<b>18</b>

## **LIST OF TABLES**

	<b>page</b>
<b>Table 2-1 DCS Input and Output Signals</b>	<b>6</b>
<b>Table 2-2 DCS OSDPD Job Descriptions</b>	<b>15</b>
<b>Table 2-3 DCS Error Reporting</b>	<b>21</b>
<b>Table 3-1 DCS Problems and Possible Solutions</b>	<b>25</b>
<b>Table A-1 DCS Purchase Costs</b>	<b>28</b>
<b>Table A-2 DCS Current Yearly O&amp;M Costs</b>	<b>28</b>
<b>Table A-3 DCS Equipment List</b>	<b>29</b>

# ***PRELIMINARY***

## **1 Introduction**

### **1.1 Document Purpose**

This document presents the interim findings of a study conducted by Mitretek Systems which characterized the configuration and capabilities of the GOES Data Collection System (DCS). The GOES DCS consists of Radio Frequency (RF) equipment to send and receive the signals and the DCS Automatic Data Processing System (DAPS). The DAPS hardware, software and database went operational at the Wallops Command and Data Acquisition (CDA) Station in 1989, replacing the earlier generation system. The focus of the Mitretek study is on the portions of the system which are aging and would benefit from improvement or possible replacement. Broader aspects of the GOES DCS that extend beyond technical are considered, including systems operations, management and the user interface. Particular attention has been given to capturing the systems development, management, operations and maintenance organizational roles.

### **1.2 Document Scope**

Section 2 contains the overall GOES DCS characterization from a high level perspective, including DCS RF equipment, DAPS block diagrams and descriptions of the input and output signals, hardware, software, database, organizational roles, and error message reporting. Analysis of the GOES DCS strengths and weaknesses are presented in Section 3. Recommendations are given in Section 4 for certain areas which can be addressed in the near term; however, technical options for rehosting or replacing the system components will be presented in another or in the final study report.

## **2 Overview of Current System**

### **2.1 Mission**

The GOES DCS collects environmental data that is transmitted from over 10,000 domestic and international Data Collection Platforms (DCP). Each DCP contains one or more sensors that gather the data and then transmits it at UHF to the GOES East or West spacecraft. To use the service, a DCP must be located within the footprint the GOES, which covers most of North and South America except for the northern- and southern-most latitudes. DCS users can receive their data in real time via either a Ku-Band domestic satellite (DOMSAT), the NWS telecommunications gateway, or by having a Direct Readout Ground System (DRGS). Users can also receive their data, monthly activity reports, and modify their DCP and User data records via switched telephone circuits which connect via modems to the Wallops CDA Station. Over the past two years the Wallops personnel have included a Telenet and an file transfer protocol (FTP) capability to facilitate Internet user access.

### **2.2 Functional Description and Data Flow**

# PRELIMINARY

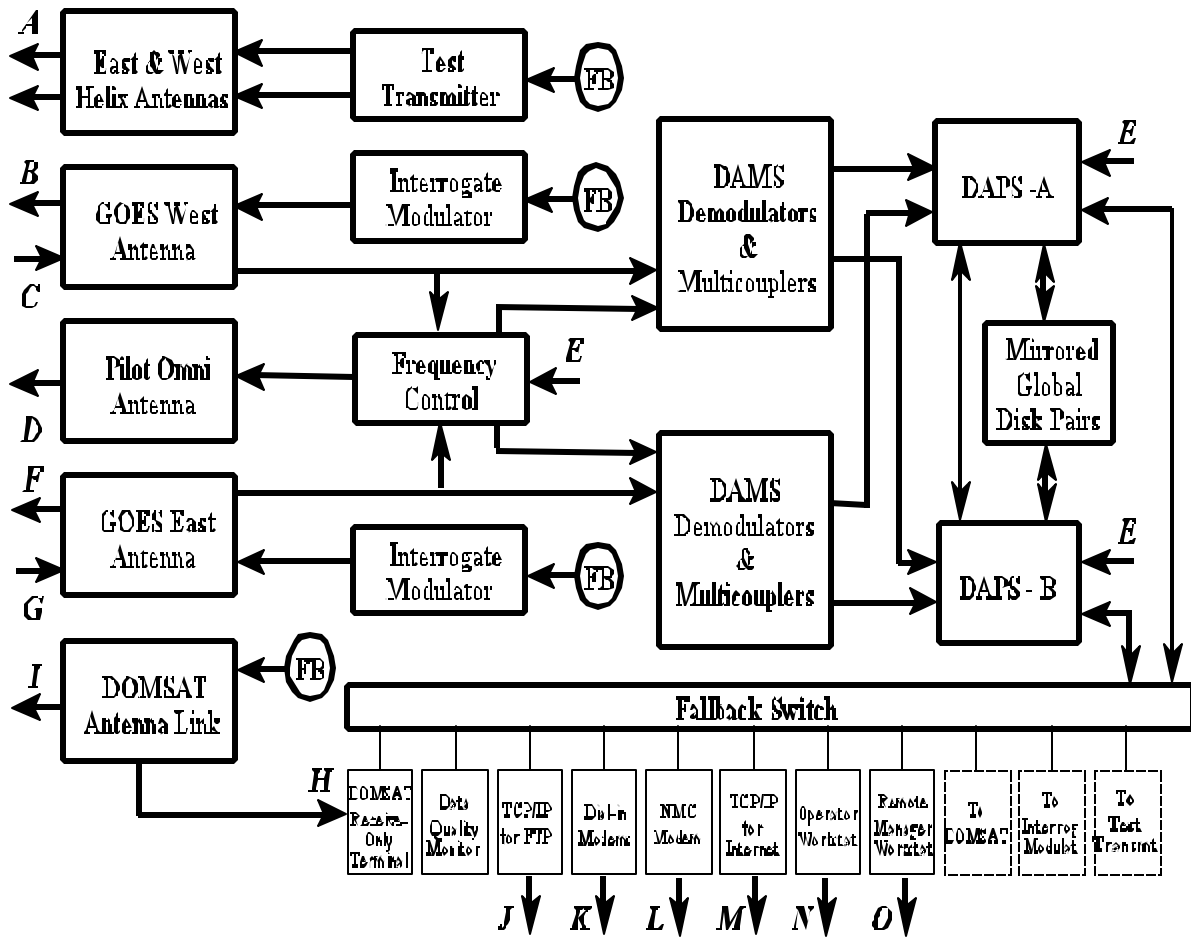

**Figure 2-1 Data Collection System Block Diagram**

Figure 2-1 provides a block diagram for the GOES DCS facility located at Wallops. It consists of an RF front end that receives DCP data from the GOES East and GOES West spacecraft and then routes this data to the DAPS. The DAPS then stores and disseminates the DCP to the DCS user community through a number of data circuits. The DAPS also commands the DCS test transmitter on every active channel at least once every two hours and sends interrogate commands to each satellite every half second. Further the DAPS maintains the data records for the system which enables scheduling, management functions and pre-defined reports to be issued periodically. More detailed subsystem descriptions are provided in the following sections and additional information are provided in the following documents:

- ! National Geostationary Operational Environmental Satellite (GOES) Data Collection System (DCS) Operational Plan, FCM-P28-1977

# ***PRELIMINARY***

- ! User Interface Manual for the GOES Data Collection System Automation Processing System (DAPS), Version 1.1, September 1990

## **2.2.1 Data Collection and Distribution**

Each DCP transmits environmental sensor data to either the GOES East or West spacecraft. Each DCP transmits at an assigned 1.5 kHz UHF frequency - 200 domestic channels and 33 international channels. Present DCPs transmit at a 100 bits per second data rate depending upon its data reporting method. The following types of DCPs are used in the GOES DCS:

- ! Self Timed, (S), that transmit data at specified times and intervals on a daily basis,
- ! Random Reporting, (R), that transmits data based upon an environmental threshold trigger that is detected as exceeded. These events occur at random and as such no regular time of reporting is established.
- ! Interrogate, (I), that transmits data in response to receiving a command from the DAPS
- ! Dual (D), a name assigned to DCPs that operate on international channels because the channel assignment is maintained on both satellites.

These signals are received at UHF and frequency translated in the S-band GOES transponder. The resulting are downlinked to the Wallops CDA station. The signals are then received by the respective GOES East or West Antenna system. The signal is amplified and down converted to a nominal 74.5 MHz DCS Intermediate Frequency (IF). The IF signal is further downconverted to a nominal 5 MHz by the DCS Interrogate and Control Equipment (DICE) which removes the satellite transponder frequency drift, and then routes the data through a multicoupler to the Data Acquisition and Monitoring Subsystem (DAMS) - data demodulators. Each spacecraft path contains a DICE and multicouplers that split each signals that are inputted into the DAMS. Presently there are eight (8) DAMS for each spacecraft and each DAMS is capable of simultaneously supporting up to 10 channels. A thumb wheel switch on the DAMS demodulator card selects the desired DCS operating frequency. This design permits any DAMS demodulator card to be placed in any chassis slot. The DAMS provide the carrier acquisition, bit and frame synchronization of the DCP data. In addition the DAMS provides the following signal quality measurements:

- ! DCP transmit EIRP
- ! DCP Transmit Frequency Offset
- ! DCP Modulation Index
- ! Received Data Quality



# ***PRELIMINARY***

The demodulated DCP data with these quality measurements appended are then transferred to both DAPS computers. Each DAPS computer will ingest, store and route the DCP. One DAPS is designated as the primary computer and the other is designated as the hot backup. The DCP data is stored on local disks on each DAPS. While the DAPS does not modify any of the data coming from the DCPs, it adds a message header which includes the date, message length, satellite channel received and S/C ID, DAMS measurements, and an error code. DAPS verifies that the DCP address is registered in the system. If yes, it continues processing and distribution of the data. If no, the DAPS modifies the address received. Thus disabling the dissemination of the message data received. The DAPS also uses the demodulated data to generate parity error alarms, and utilizes the scheduling database record for correct time and channel assignment. Quality and status information are appended to the platform data. Data from the primary DAPS is transferred through the switching circuitry to the DCS outputs that are described in Section 2-3. DAPS can store DCP data for up to 10 days on disk drives connected to the primary DAPS. Nominally user data is available for up to four days over which the DAPS can provide re-transmissions as requested by the users.

## **2.2.2 Platform Interrogation**

The DAPS issues an interrogate commands every half second to each satellite . Some of these result from a database entry, some result from a missing response from a self-timed DCP and some result from a manual request by a primary user. The interrogation requests are routed to either the GOES East or GOES West Interrogate Modulator. The Interrogate Modulator generates the phase modulated nominal 74.9 MHz IF signal that is then up converted to S band by the GOES transmitter for uplink through the antenna to the GOES. The interrogate control subsystem receive the nominal 468 MHz downlink to remove the frequency uncertainty in the GOES interrogate transponder. The resulting UHF signal can then be received by all interrogate DCPs in the footprint of the spacecraft. Only the platform with the appropriate address will respond to the interrogate request. While the interrogate system is capable of issuing commands to a DCP, the resulting DCP reply messages are similar to those of the other DCP types.

The interrogate signal transmitted every half second not only contains a DCP address but also a four bit National Institute of Standards and Technology time code signal. The GOES time code requires 30 seconds to capture or 240 data bits.

## **2.2.3 DCS Calibration and Self Testing**

### **Pilot Signal**

To compensate for frequency drift in the spacecraft DCS transponder and to adjust the overall system gain a 401.085 MHz UHF pilot signal that is referenced to the Wallops timing system is transmitted to both the GOES East and West spacecraft via a Omni directional antenna. The spacecraft processes this signal like a regular platform signal and the resulting S-band signal is detected and processed at each of the GOES receive antennas. The DICE Pilot Control Subsystem (DCPS) detects this IF signal and uses its phase

# ***PRELIMINARY***

lock loop to adjust the downlink signal to 5 MHz. This frequency corrected 5MHz is then applied to the multicouplers and on to all DAMS chassis.

## **Test Transmitter Signals**

The DAPS schedules test messages on every active DCS channel every two hours. This message simulates a DCP signal. The test transmitter is frequency agile and generates the message based upon a DAPS command. After issuing the command the DAPS then looks for the respective message and does a byte by byte compare with the message sent. If an error is detected an alarm is generated on the operator's console. To uplink the message the test transmitter uses either the GOES East or West helix antennas.

## **2.3 External User Interfaces**

Table 2-1 provides a summary of the DCS external interfaces. RF signals that are represented by the designations A-D and F-G are discussed in Section 2.2. Users can receive their data by any of several means, including: dedicated lines, dial-up modems, DOMSAT Receive-Only Terminals (DROT) via DOMSAT, or DRGS.. The DRGSs do not obtain their data via the Wallops DCS facility but rather obtain it directly from the GOES spacecraft. In general a DRGS receives no more than 10 channels of DCP data simultaneously. The DGRS is used by the DCS user community as either a backup to the Wallops or as a primary message reception approach with the DOMSAT and Wallops as secondary. The other ways to receive DCP data are highlighted below.

### **DOMSAT Input (H) and Output (I)**

All DCP messages ingested by the DAPS are formatted for output to the Ku-band DOMSAT output. To quality control this link a Data Quality Monitor is connected to the DAPS. Accordingly the DAPS checks the pointers from the messages output with those received via the DQM. Should there be a discontinuity the DAPS will reset the pointers and re-broadcast the DCP message data. The DOMSAT interface also allows DOMSAT users to request retransmissions of selected portions of their data. To do this the user must be a DOMSAT user. The user then interfaces with the DAPS via switched telecom or via the INTERNET and sends the retransmit request. As part of the DAPS project a DOMSAT Receive Operator Terminal (DROT) was developed. This was done as a first generation method to enable user to realize the potential of the DOMSAT communications link. Since that time the DROT software has undergone modification and improvement. Currently there are over forty DROT's in operation by the user community. It is the most cost effective way to receive real-time GOES DCS data.

## ***PRELIMINARY***

**Table 2-1 DCS Input and Output Signals**

<b>Design</b>	<b>NAME</b>	<b>I/ O</b>	<b>Source/ Destination</b>	<b># of Signals</b>	<b>Frequency (MHz)</b>	<b>Characteristics</b>	<b>Comments</b>
A	Test Transmitter	O	GOES East & West DCPR Receiver	2	401.710 to 402.0985	Tunable 100 bps signal that can be sent at any of the DCP transmitting frequencies	Includes canned test message
B	GOES West Data Collection Platform Interrogate (DCPI)	O	GOES West DCPI Receiver	1	2034.9	Signal sent to interrogated DCPs to enable DCP to send data	
C	GOES West Data Collection Platform Reply (DCPR)	I	GOES West	1	1694.3 - 1694.7	100 bps DCP signals relayed through the GOES West S/C	Test signal and pilot signal also received from GOES via this signal
D	Pilot Signal	O	GOES East & West	1	401.85	100 bps signal relayed through GOES spacecraft	Frequency shift between transmitted and received signal compensates for S/C transponder drift
E	Station Timing	I	DCS	3	5	Station timing frequency standard	

## ***PRELIMINARY***

**Table 2-1 DCS Input and Output Signals**

<b>Design</b>	<b>NAME</b>	<b>I/ O</b>	<b>Source/ Destination</b>	<b># of Signals</b>	<b>Frequency (MHz)</b>	<b>Characteristics</b>	<b>Comments</b>
F	GOES East Data Collection Platform Interrogate (DCPI)	O	GOES EAST DCPI Receiver	1	2034.9	Signal sent to interrogated DCPs to enable DCP to send data	
G	GOES East Data Collection Platform Reply (DCPR)	I	GOES East	1	1694.3 - 1694.7	100 bps DCP signals relayed through the GOES West S/C	Test signal and pilot signal also received from GOES via this signal
H	DOMSAT DCS Users Downlink	I	DOMSAT	1	12 GHz	56k bps x.25 signal from DCS via GE Americom S/C	Provides information from all DCS platforms and electronic mail messages to users and to the DQM via the DROT
I	DOMSAT DCS Users Uplink	O	DOMSAT	1	14.029 GHz	56 kbps x.25 signal from DCS to GE Americom S/C	Provides information from all DCS platforms and electronic mail messages to users
J	FTP Interface	I/O	DCS Users & DCS	1	N/A	TBD bps interface with Internet	New DG board installed in MV20000 chassis

## ***PRELIMINARY***

**Table 2-1 DCS Input and Output Signals**

<b>Design</b>	<b>NAME</b>	<b>I/ O</b>	<b>Source/ Destination</b>	<b># of Signals</b>	<b>Frequency (MHz)</b>	<b>Characteristics</b>	<b>Comments</b>
K	Dial In Modems	I/O	DCS Users & DCS	9	N/A	300,1200,2400 & 9600 dial in lines	Provides external dial in interface to DAPS to retrieve DCP messages, request retransmission via DOMSAT, update & display tables, interrogate platforms, & communicate with DCS manager or operator
L	NWS Gateway	I/O	DCS Users	1	N/A	4800 bps RS-232	Interface to NWS modem
M	Internet	I/O	DCS Users	1	N/A	TBD bps interface	New DG board installed in MV20000 chassis
N	Wallops Operator	I/O	DCS Operator & DCS	3	N/A	RS-232 asynchronous full-duplex interface	Interface to DCS Operator terminals, PC emulators and printers
O	Remote Manager	I/O	DCS Manager & DCS	5	N/A	9600 bps asynchronous full-duplex data streams mux/demuxed into one synchronous	Interface to Remote Manager terminals and printers at Suitland via dedicated 9600 bps line

# ***PRELIMINARY***

## **File Transfer Protocol (FTP) Interface (J)**

Over the past two years a TELNET and FTP capability have been under development. Additional capabilities and modifications to existing capabilities will be implemented as DCS users operations, management, and maintenance personnel begin to use these capabilities. Presently users can send requests to Wallops for DCS data from specific platforms during specific intervals. Wallops personnel are configuring the DCS to generate files that contain the data and then transfer the data to the users at the end of these intervals. Users can use this interface in similar manner to the switched telephone circuits described below to send files, do database platform updates, to the DCS via this interface.

## **Dial In Modems (K)**

The DAPS originally had ten (10) dial-in lines were available for DCS users to receive DCP data and for primary user/owners to update their PDT and UDT records. However, in order to implement the FTP capabilities highlighted above the number of dial in circuits had to be reduced accordingly. The dial in circuits have also served as backup for operations and management personnel. The commands, platform updates, message retrieval processes, interrogate requests, E-Mail, etc. are defined in the DAPS User Interface Manual.

## **NWS Telecommunications Gateway (L)**

The DAPS has a unique interface with the National Weather Service's Telecommunications Gateway (NWSTG) . Most DCP data is routed through a dedicated conditioned telecom circuit via modem to the NWS Silver Spring MD headquarters. The NWSTG circuit also has a backup dial-in phone line in the event of a failure to the dedicated circuit. The NWSTG uses a X.25 type circuit and a WMO header format that wraps the data for transmission to the NOAAPORT and to other NWS forecast offices. The NWSTG data format has been in use for over twenty years.

## **Internet (M)**

Over the past year a DCS Internet capability is under development. Recently TCP/IP boards have been installed in the DAPS. Additional capabilities and modifications to existing capabilities will be implemented as users, operators, managers, and maintenance personnel begin to test using the Internet to access DCS.

## **Operators at Wallops (N)**

The man-machine interface to the Data General MV 20000 is via terminals at Wallops CDA. These terminals are used by hardware maintenance, software, and operations personnel to monitor DCS status, conduct periodic testing, and resolve hardware and software anomalies. Personal computers are also connected to the DCS and these computers contain software that emulates the DCS operator interface.

## **Remote Manager @ FB-4(O)**

One dedicated telephone line is used to provide access to the DCS by management personnel at FB-4. The dedicated 9.6 kbps circuit has a four to one multiplexer enabling three lines to be supported two terminals and one print port. The terminals at FB-4 are implemented with standard PCs running a DG terminal emulator. The terminals are used by management personnel to monitor DCS status, collect

# ***PRELIMINARY***

information for status reports and modify and assign DCS channels. All the capabilities of the terminals at Wallops are available on the FB-4 terminals. A single personal computer is connected to the third telephone line and contains software that emulates the DCS user interface. Through this PC the manager can act as a user to troubleshoot problems or via the emulator software use the PC as a backup should the dedicated circuit fail.

## **2.4 DAPS Hardware**

DAPS is hosted on dual Data General MV20000 32-bit computers running the AOS/VS operating system and uses the DG/SQL database. Figure 2-2 is a block diagram of the DAPS. The dual DG MV20000 computers are interconnected within the DCS via an automatic fallback switch that allows the backup computer to replace the primary computer in the event of a failure. An intelligent LAN controller and Watchdog software monitor the system operation and command the switch to operate when a failure is detected. An RS 232 interface is used as a backup to the LAN circuit. The fallback switch can also be commanded manually by the DCS operator.

In the normal configuration, the automatic fallback switch provides redundant operation between the primary and backup DAPS computers with both processing and storing DCP message data locally. The conditions that trigger the switch to are the following:

- ! Failure of the primary DAPS front end to receive data from the DAMS
- ! Failure of the real-time process on the primary DAPS
- ! Failure of the interprocess communication between primary and backup DAPS

The fallback switch controls the connection of the operator console monitors, remote manager terminals, printers, output ports, and mirrored pairs of global disk drives between the DAPS A and DAPS B computers. During normal operation, both DAPS A and DAPS B computers receive and process all DCP reporting data in real time, and store the data on local disk drives. The global disks are shared by both DAPS computers, but only the primary DAPS computer has write access to the Global Message Directory (GMD) and Global Message Storage (GMS) files on the disks. The primary DAPS computer handles all system processes and all data dissemination interfaces.

The two DAPS computers can be operated in a split system configuration with individual devices, such as an operator console monitor, switched manually to the backup system. When the system is operated in the split configuration mode, any changes to the database tables resident on the global disks are not made to the backup computer local disks. When the system is rejoined, the local drives on the backup computer must be reinitialized with the current version of the database from the

**PRELIMINARY**

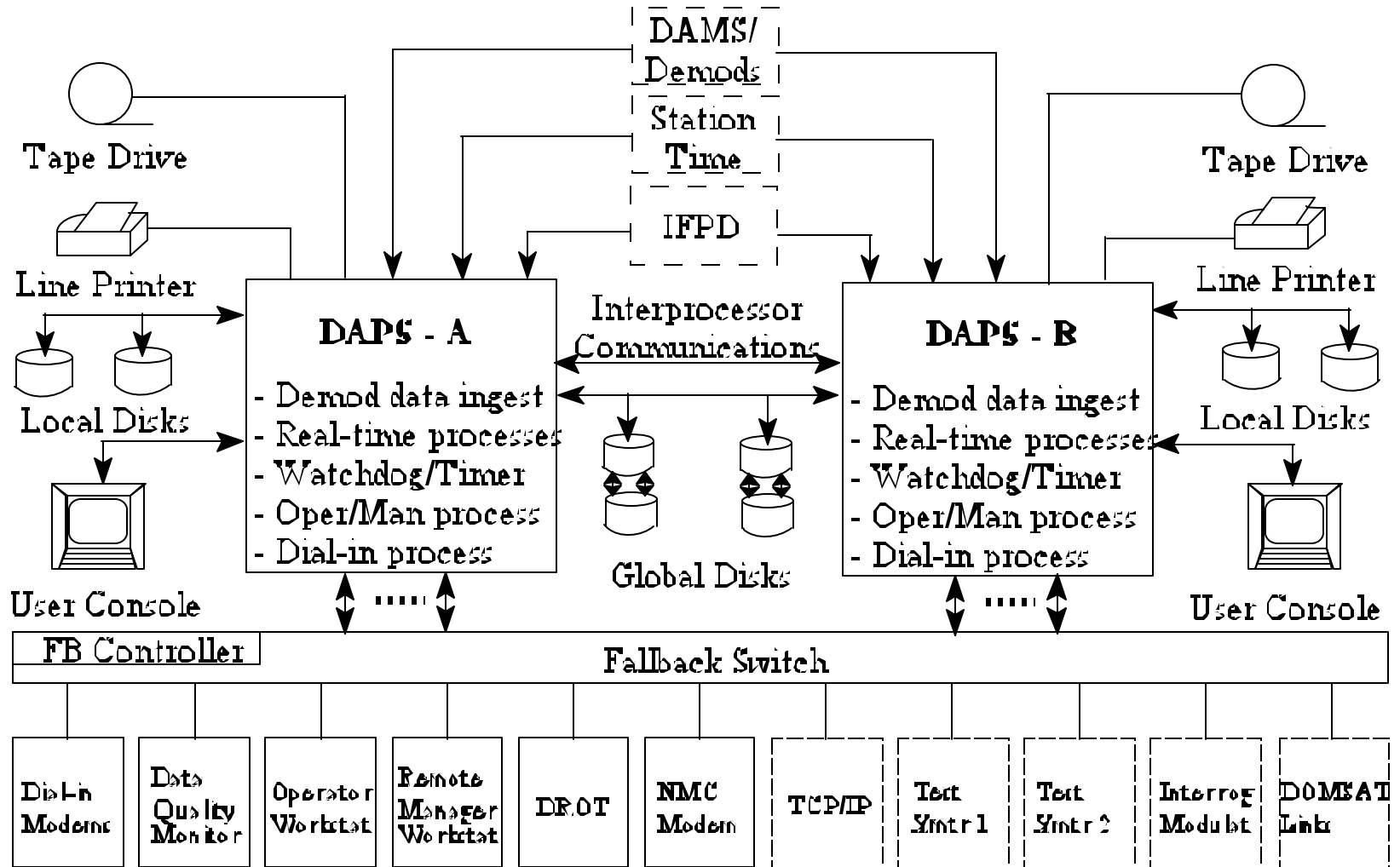

**Figure 2-2 DCS Automatic Processing System Block Diagram**

system disks to capture the changes. The disk drives record a high volume of realtime message traffic, and drive failures have become a



## ***PRELIMINARY***

problem in the past. To remedy the problem, all the disk drives were upgraded to 2.1 GB SCSI Seagate drives in 1995. The application software was not modified to store additional data beyond the original requirements of three days of data with ten days maximum, so the extra installed capacity is not utilized. The users originally requested 21 days of data storage. The new drives have approximately four times the capacity as the ones they replaced.

### **2.5 DAPS Software**

The DAPS software can be separated into the three categories of operating system, applications code, and database management system. The operating system is Data General AOS/VS version 6.64, which is the same version that was installed in 1989 upon the completion of the DAPS. While this version of AOS/VS is not the current one available from DG, it was an intentional decision on the part of the DCS program not to remain current. The line of reasoning being that upgrades to the OS the DCS could make modifications to the application code necessary. The strategy has paid off in one sense, the system continues to operate with a high availability using the original version. Unfortunately there is a potential for a Year 2000 (Y2K) bug which can be remedied by a patch for the current OS version. Wallops personnel are currently performing Y2K testing on the system.

#### **Applications Code**

The DCS application code is written in Fortran 77 and compiled on the DAPS DG. The code is modular with separate files for commons, include file declarations, and procedures. The Y2K problem is believed to also affect the DG FORTRAN compiler, and if so, the code would need to be recompiled with the new patched compiler version, following installation of the patched operating system version. This will require additional testing to determine if changes are needed to the application code to operate beyond 2000.

In the normal DCS configuration, only the primary DAPS is running the REALTIME process to receive and distribute DCP message data to users via dial-in sessions, DOMSAT, or NWSTG, and read and write data on the global disks. Both primary and backup DAPS run the FE (front end) process to ingest the data from the DAMS demodulators, the OP (operator) and PMGR (manager) processes for system control, and the WATCHDOG and CLEANUP processes.

#### **Database Management System**

The DAPS data management system comprises two different and distinct parts. First, data from the remote platforms (the DCP data) is stored online on the shared mirrored paired disks. Second, DCS control and administration data is stored in an SQL database. Both types of data are constantly accessed during operation.

## ***PRELIMINARY***

### **Platform Message Data Management**

A single data transmission from a remote platform, augmented by a header that also contains certain quality information, is known as a message. Both external users and the system access these messages. Data management of the messages is relatively simple. One disk of each mirrored pair contains pointers to the actual message locations on the other disk. As DAPS receives and processes the messages, it writes the data and data pointers to the disks. By virtue of the circular nature of the message files, older data gets overwritten by newer data. Currently, approximately ten days worth of messages are stored. The disk drives have room for substantially more data.

The system queues message data on local disks before writing it to the mirrored pairs. If there is a switch over from the primary to backup side, the mirrored pair data can usually be reconstructed from the queue on the backup. Thus the integrity of the message data has been extremely high over the life of the system. From the GOES DCS records only about ten hours of DCP message has been lost since the system began operation in 1989; and of these five were lost running tests, not actual failure events. The high degree of message integrity is considered an essential feature of the system by its operators.

### **DCS Control and Administration Data Management**

Control and administrative data are contained in a proprietary Data General SQL DBMS (Database Management System). These tables store information on users, platforms, channels, MOAs, and DCS performance statistics. There are approximately fifteen tables, three of which are linked by foreign keys, occupying about 25-30 MB of disk space. A number of these tables reside in memory to enable real-time access and update. This is necessary because, for each message from each platform, the system checks the Platform Description Table, the User Description Table, and the MOA Table to make sure that the user and platform are authorized, and that the platform is using its assigned time slots and frequencies (the message is still stored if it uses the wrong time slot or frequency, but the header quality data reflect such errors). Since there could potentially be more than 200 channels reporting at any one time slot (e.g., within less than a minute), it would be difficult to assure access to the data in these tables fast enough if they were not cached in memory. Caching also greatly reduces the wear on the local disk drives.

The DG DBMS is proprietary and uses a non-standard SQL dialect. It maintains the cache and synchronizes the tables between cache and memory. It runs scripts and reports interactively using a DG proprietary user interface called PRESENT. PRESENT scripts and reports only run inside the interactive PRESENT environment. In particular, they apparently cannot be run from the command line or batch files. To access the data tables from the command line or from batch files, FORTRAN programs are used containing embedded SQL commands. A number of important reports operate this way.

## ***PRELIMINARY***

To access data in these tables from outside of the DAPS, it appears that FORTRAN programs must be written. It may be possible to arrange for a FORTRAN program to use text input from a file or keyboard in constructing an SQL select statement to access data. These access methods restrict how access may be extended, e.g., via the INTERNET.

### **2.6 DCS Roles and Responsibilities**

***PRELIMINARY***

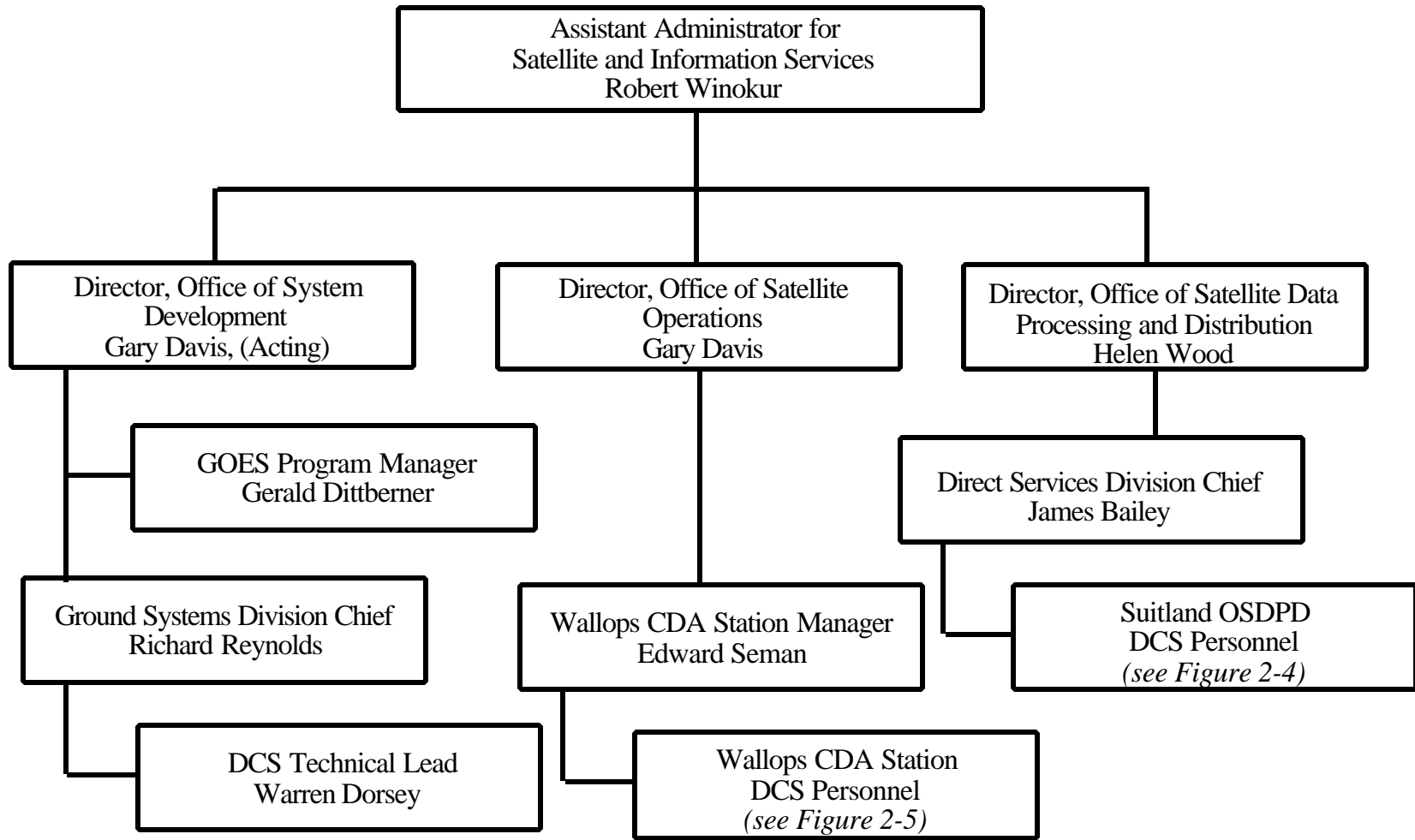

**Figure 2-3 NESDIS DCS Organization**

Figure 2-3 shows the overall DCS program relationships among the NESDIS organizations at Suitland and Wallops.

# ***PRELIMINARY***

## **2.6.1 DCS Management at Suitland**

Table 2-2 provides all the OSDPD DCS job descriptions and Figure 2-4 provides an organization chart of DCS personnel within OSDPD. Dane Clark is the Data Services Division Team Leader in OSDPD, responsible for a variety of satellite data services including DCS. Marlin Perkins is the DCS Program Manager, Kay Metcalf is the DCS Coordinator and Carol Dash is the DCS Analyst.

**Table 2-2 OSDPD DCS Job Descriptions**

<b><u>Name</u></b>	<b><u>Title</u></b>	<b><u>Job Description</u></b>
Dane Clark*	Data Services Team Leader	Manages personnel and processes MOAs
Carol Dash	DCS Analyst	Making channel assignments, updating PDTs, and limited MOA processing
Kay Metcalf	DCS Coordinator	Updates databases & user files, interfaces with users
Marlin Perkins	DCS Program Manager	Manages personnel, processes MOAs, and interfaces with users; supports STIWG
James Wydick	DCS Consultant/Contractor	Advises management on policies and best practices
PRC	Computer Analyst/ Contractor, <i>Vacant</i>	TBD
PRC	Analyst/Contractor, <i>Vacant</i>	TBD

\* Also manages WEFAX, GOES Direct, NOAA PORT, ARGOS, Polar Direct, EBB

The division of responsibilities between OSDPD at Suitland and OSO at the Wallops CDA is consistent with the other GOES and Polar Systems. However, unlike all the other systems most of the DCS hardware and software is at Wallops so some of the responsibilities that are normally performed at Suitland have been performed at Wallops. OSDPD is responsible for insuring that DCS data is delivered reliably and accurately to the users, performing all user interface functions like making channel assignment, generating and updating MOAs and PDT assignments, analysis of DCS performance, generation of management/system status reports, etc. OSDPD has performed these functions for over 18 years. However, recent the loss of key personnel due to retirements, temporary funding problems that prevented the training of new personnel, and the loss of documentation during the DCS moves from the World Weather Building to the Princeton building and then to FB-4 have led to some of these monitoring functions to not being performed at either Suitland or Wallops.

Daily analysis of the DCS errors, status, measurements, statistics etc. are not being performed because of the problems discussed in the last paragraph. Also trending and tracking of this data over longer periods of time are not being performed. Knowledge and understanding must be gained about what CLI and Present macros to run and how to run them in order to collect and analyze this data. Using this data

## ***PRELIMINARY***

OSDPD personnel would work with Wallops personnel to solve problems together and this teaming arrangement has suffered as these shared tasks were not being performed.

***PRELIMINARY***

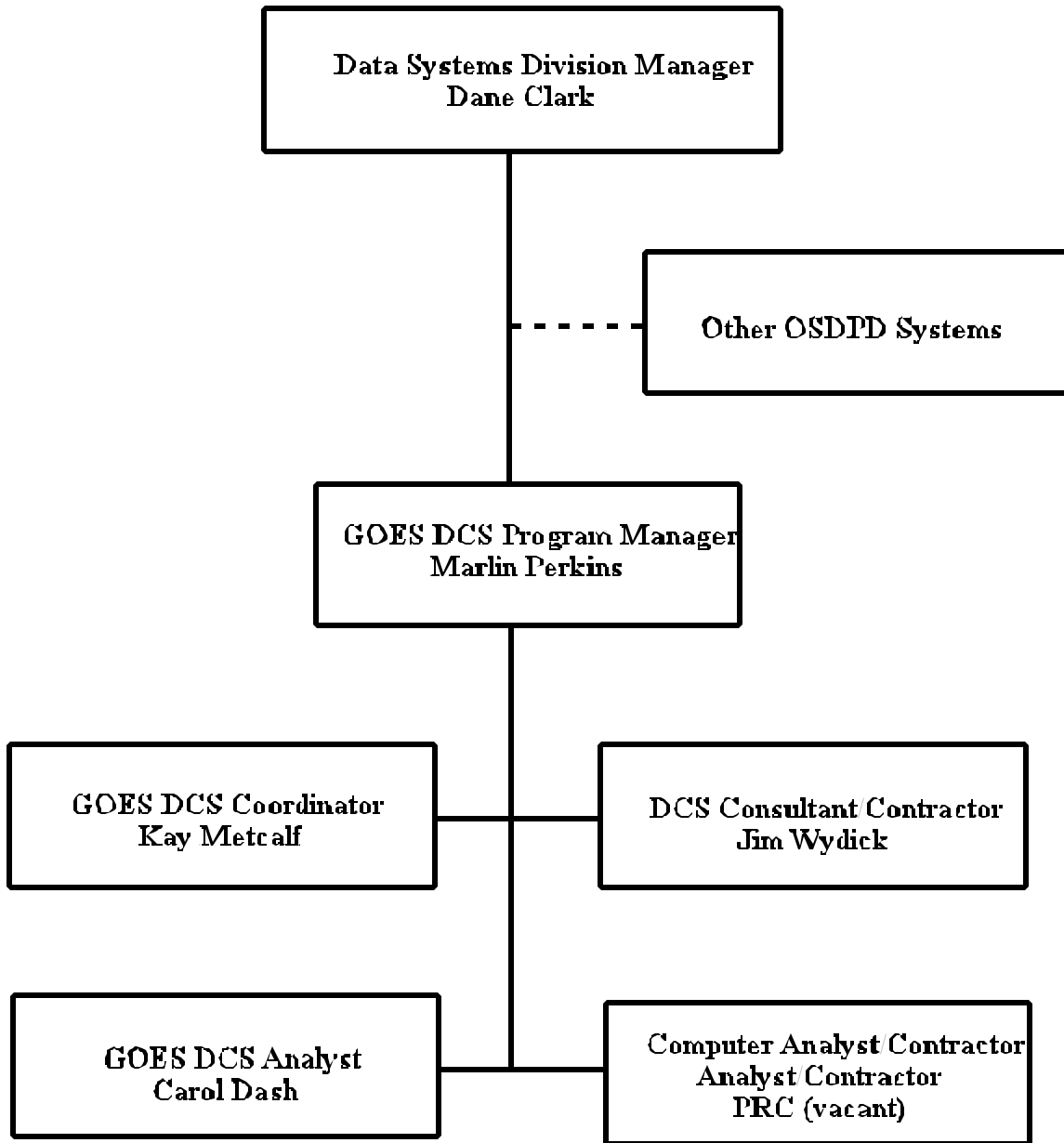

**Figure 2-4 OSDPD DCS Organization**

## ***PRELIMINARY***

During the period when OSDPD DCS positions were not filled, Wallops personnel continued performing their tasks with minimum contact with the remaining ODSPD DCS personnel. When OSDPD started staffing up again the close Wallops and ODSPD working relationship had been lost. This good working relationship needs to be recreated. For example:

- C Wallops DCS operational personnel need to notify Suitland when they plan or have to reconfigure DAPS This will minimize work being performed needlessly at Suitland.
- C OSDPD DCS personnel should receive a copy of the DAPS system operations log from Wallops on a periodic basis

The DCS user interface is very antiquated (i.e., The interface is text based only.) There is no mouse for point and click, etc. Backspace for correction of an incorrect data entry cannot be performed.) This reduces the efficiency of the new OSDPD DCS personnel who not only have to learn how to operate and maintain the DCS but have to do so on an antiquated and system where processes need to be re-learned.

### **2.6.2 DCS Operations at Wallops**

DCS real-time operations are conducted at Wallops by OSO. Figure 2-5 depicts the organization of operations and maintenance personnel available to support DCS. Operators log in and manage the system through either the MV20000 console monitors or via DOS-based terminal emulators running on desktop PCs. Microsoft Windows and mouse device are not supported. A commonly heard complaint is that the user interface is clumsy with only a line editor which has no backspace function. There is an ongoing development effort at the WCDAS to improve user access to the DCS database tables and the user platform data via the Internet and by FTP interface described above. A user can access the DCS database to update information in the corresponding User Description Table (UDT) and Platform Description Table (PDT). Some fields in the database are locked and must be updated by either the DCS operator or manager.

The DCS operators are a part of the GOES/POES crews and report to their respective shift supervisors. George Linvill is one of the four shift supervisors that has significant experience with the DCS program, and as such is designated the DCS hardware supervisor. Al McMath is the computer software specialist that performs much of the DCS system administration, in addition to operations. Cy Settles is the DCP certification officer and performs other technical duties especially in the RF front end of the GOES DCS. All these roles contribute to the success of the DCS.

### **2.6.3 DCS Users**

The GOES DCS serves domestic and international government agency users exclusively, including NOAA, the U.S. Geologic Survey, Army Corps of Engineers, Forestry Service, National Data Buoy Center, the National Meteorologic Center and others. The major GOES DCS users are represented via the Office of the Federal Coordinator for Meteorology's Satellite Telemetry Interagency Working Group (STIWG)



## ***PRELIMINARY***

which that meets periodically to enable the users to participation in the sharing of

***PRELIMINARY***

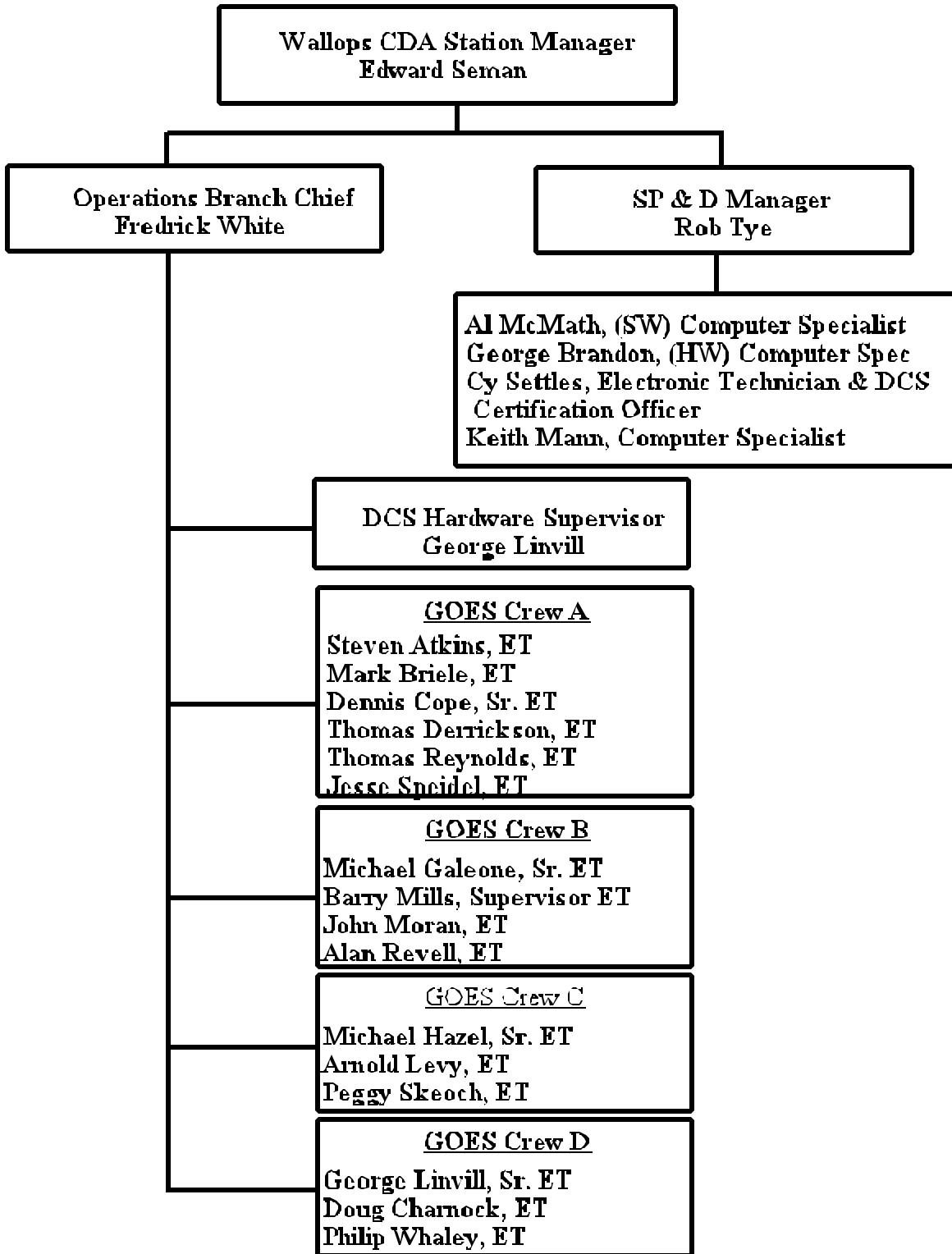

Figure 2-5 OSO DCS Organization

# ***PRELIMINARY***

information and to consolidate the federal users interests for enhancements to the GOES DCS. Some of which the STIWG has funded. The primary users own and operate the platforms, while secondary users make use of the data as available. The DCS collects data from remote platforms, such as river gauges or ocean buoys, and processes and distributes the data to users automatically.

While DCS has the capacity to support 100,000 platform descriptions in the PDT, there are approximately 14,000 DCPs registered with 8000-9000 active. DCS can support up to 5000 user descriptions in the UDT. Overall system loading is not a problem, but there can be congestion because some reporting times are more desirable for modeling purposes, such as daily at noon for example. This can complicate the process of scheduling channels for new user platforms. User demand appears to be fairly level in recent years, and that may be attributed to several possible reasons, such as, refined user models requiring fewer data sampling points, increased sharing of data among users, or data available from other sources. SHEF codes were an early attempt to standardize the data format used by DCS platforms so that user data sharing would be facilitated.

The data transmitted from DCS is in the same format as it was received from the platform, with only a header attached to record the time and date. The date is added with a two digit year format which is a Y2K concern. No further processing is performed on the data by DAPS. A GE Americom DOMSAT 56 kbps link is used to transmit all the DCP data received to DROT's located at equipped user sites. At WCDAS a Data Quality Monitor (DQM) is used in conjunction with the DOMSAT output to detect whenever there is a problem with the DOMSAT transmission. Users may request retransmission of data at any time for up to three days. The same as with the dial in lines. The database is backed up nightly, but there is no provision for long term archiving of data. There have been a few cases of users requesting information on out-of-date data, such as whether a certain DCP was reporting on a specific date.

Users with DRGSs have a subset of the DCS system capability. These systems receive the 401.85 MHz pilot and 1694.5 MHz DCS signals directly from the GOES spacecraft using a 12-15 foot paraboloidal reflector (dish). Most DRGS' have a demodulator shelf that can handle one or more channels in a manner similar to the way DCS does. In the event of a DCS ground system outage, DRGS users can continue to receive selected data provided that the pilot signal is still being transmitted from WCDAS.

## **2.7 Errors and Failure Recovery**

The DCS performs with continued high reliability and low data loss, thanks to the dedication of the Wallops operations team. The operators have thorough knowledge with the system and changes to the system functions have been gradual. The user interface is not easy to use, but operators are well trained with it and can perform even the most difficult tasks. Note operations would have to re-learn any new interface that might be incorporated into the DAPS. Table 2-3 lists the data message transmission and composition errors that can be detected by GOES DCS. In the event of a switch between primary and backup systems, there is usually a brief period, up to 90 seconds, when data is not flowing to the users. Following completion of the switching process, the DAPS back sets the pointers for 90 seconds and resumes the data flow with no data loss. There have been instances of system hangs following the switch over when

## ***PRELIMINARY***

the global system disks failed to remount properly with

# ***PRELIMINARY***

**Table 2-3 DCS ERROR REPORTING**

<b>SIGNAL/ERROR</b>	<b>SOURCE</b>	<b>DESCRIPTION</b>	<b>COMMENTS</b>
DCP Transmit EIRP	DAMS	Compares signal strength from each DCP with the pilot signal. 16 bits (2 ASCII characters) assigned for this value	If received signal is out of range a // will be inserted for the signal strength
DCP Transmit Frequency Offset	DAMS	Determines how much does the DCP frequency deviates from its assigned frequency in increments of 50 hz. 16 bits (2 ASCII characters) assigned for this value	If the received signal frequency is > 500 hz an <b>A</b> will be inserted in the 2 <sup>nd</sup> ASCII character
DCP Modulation Index	DAMS	Determines if the modulation index from each DCP is normal, low, or high 8 bits (1 ASCII character) assigned for this value	3 characters are provided, <b>H, N &amp; L</b>
Data Quality	DAMS	Determines if the bit error rate from each DCP is normal, fair, or poor 8 bits (1 ASCII character) assigned for this value	3 characters are provided, <b>N, F &amp; P</b>
Parity errors	DAPS	Detects a parity errors in the DCP message 8 bits (1 ASCII character) in Failure Code Field sent to DCP users	1 character ? provided
Message received in wrong channel	DAPS	Detects messages from DCP were ingested in the wrong channel 8 bits (1 ASCII character) in Failure Code Field sent to DCP users	1 character <b>W</b> provided

## ***PRELIMINARY***

<b>SIGNAL/ERROR</b>	<b>SOURCE</b>	<b>DESCRIPTION</b>	<b>COMMENTS</b>
Message received on multiple channels	DAPS	Detects duplicate messages from DCP were ingested on multiple channels 8 bits (1 ASCII character) in Failure Code Field sent to DCP users	1 character <b>D</b> provided
Message received with <b>correctable</b> address errors	DAPS	Detects DCP address error but DAPS error correction recovers data 8 bits (1 ASCII character) in Failure Code Field sent to DCP users	1 character <b>A</b> provided
Message received with <b>non correctable</b> address errors	DAPS	Detects DCP uncorrectable address error (1 ASCII character) in Failure Code Field and error is not sent to DCP users	1 character <b>B</b> provided
Message received with <b>invalid DAPS</b> address errors	DAPS	Detects invalid DCP address (1 ASCII character) in Failure Code Field and error is not sent to DCP users	1 character <b>I</b> provided
Message received late/early	DAPS	Detects DCP message was received late or early, partially in its window but straddling the adjacent time slot (1 ASCII character) in Failure Code Field sent to DCP users	1 character <b>T</b> provided
Unexpected message	DAPS	Detects presence of an unexpected message from a Type S or I DCP (1 ASCII character) in Failure Code Field sent to DCP users <b>Test transmitter error not sent to DCP users</b>	1 character <b>U</b> provided

## ***PRELIMINARY***

<b>SIGNAL/ERROR</b>	<b>SOURCE</b>	<b>DESCRIPTION</b>	<b>COMMENTS</b>
Missing message	DAPS	Detects absence of an expected message from a Type S or I DCP (1 ASCII character) in Failure Code Field sent to DCP users <b>Test transmitter error not sent to DCP users</b>	1 character <b>M</b> provided
PDT entry not complete	DAPS	Detects incomplete PDT entry for this DCP (1 ASCII character) in Failure Code Field sent to DCP users	1 character <b>N</b> provided
Test Data Compare or Parity Error	DAPS	Detects data compare or parity error on <b>test transmitter</b> DCP message for the channel under test (1 ASCII character) in Failure Code Field and error is not sent to DCP users	1 character <b>C</b> provided
Bad Quality Measurements	DAPS	Detects data quality error on <b>test transmitter</b> DCP message for the channel under test (1 ASCII character) in Failure Code Field and error is not sent to DCP users	1 character <b>Q</b> provided

the primary DAPS computer. This has been a primary cause of data loss.

### **2.8 Configuration Management**

There is no formal configuration management program in effect for GOES DCS. This makes it difficult for remote managers to monitor the system modifications as split system operations and TCP/IP connection tests are conducted. Since there has not been major DAPS upgrades, much of the system documentation dates from that period when the DAPS was developed. Over time there have been incremental improvements, such as DAPS disk replacement and, most recently, installation of TCP/IP boards with INTERNET into the MV20000 computers. These system changes need to be incorporated in system documents that are available to the system operators, managers and the user community. Efforts to make system documentation more widely available are important, such as providing the DCS User Interface

# ***PRELIMINARY***

Manual online via the Internet.

## **3. Recommendations**

Table 3-1 lists a set of recommendations that resulted from the DCS characterization. In addition, the following improvements should be performed by OSDPD personnel:

- C The platform data tables (PDTs) are largely out-of-date, with incorrect points of contact, latitudes, and longitudes, due to the difficulty owners of DCPs have updating them via the antiquated interface mentioned above. Out-of-date PDTs undermine the secondary user's faith that the data retrieved has value. OSDPD personnel should communicate with DCP points of contact to verify the data items and update PDTs and UDTs, if necessary. This information, owner name, user id, latitude, longitude, contact telephone number, etc, should be kept in a DCS electronic database.
  
- C Administration of memorandum of agreements (MOAs) is paper-based. There is no electronic procedure for tracking them; and no automated alert when an MOA is close to expiring. OSDPD DCS personnel should begin data entry of MOA information into a modern electronic database management system and set up procedures for electronic tracking for all MOAs as soon as possible.
  
- C Interfacing with non English speaking DCS users causes difficulties for both DCS personnel and the users. The current system does not facilitate update of PDTs by foreign speaking owners of DCPs.
  - < A frequently asked questions (FAQs) web page should be developed in English, French, and Spanish, etc.
  
  - < Additionally, the OSDPD DCS voice mail system should allow callers to make a language selection



## ***PRELIMINARY***

**Table 3-1 DCS Problems and Possible Solutions**

<b><u>Problem</u></b>	<b><u>Description</u></b>	<b><u>Short Term Solutions</u></b>	<b><u>Long Term Solutions</u></b>
Year 2000	DCS has year 2000 problems	Test and fix (if necessary) after DG provides operating system patch	None
Wallops and Suitland coordination	Information not being shared between organizations.	Weekly video conference status meetings between Wallops and Suitland and weekly summary reports by each organization (includes all hardware and software failures and corrections).	Continue to meet
Some OSDPD Operations and Management functions no longer being performed	System monitoring functions and data base updates formerly performed by Mike Nestlebush have ceased	Hire Mike Nestlebush as consultant to teach and document procedures	Define management and operational requirements on new or re-hosted DAPS
DCS Roles and Responsibilities	No clear agreement on roles and responsibilities between Suitland & Wallops especially with DCS user interface. No central point of contact for DCS	Review previous MOA between organizations and update as necessary	Make sure these capabilities are on new or re-hosted DAPS

## ***PRELIMINARY***

**Table 3-1 DCS Problems and Possible Solutions**

<b><u>Problem</u></b>	<b><u>Description</u></b>	<b><u>Short Term Solutions</u></b>	<b><u>Long Term Solutions</u></b>
Anomaly detection	Wallops relies on DCS users to identify certain problems.	Learn from Mike Nestlebush how to run daily reports to detect problems before users contact DCS operators	Make sure these capabilities are on new or re-hosted DAPS
Suitland voice mail system deficiencies	Users complain that their calls are not returned	Still under investigation	TBD
Graphical User Interface for Management and Operations	PDTs are out of date because of the complex syntax of the text based interface (e.g.-no backspace allowed). There's no drag and drop. There's not even a mouse for such an operation. No easily run procedure to visually monitor system status.	Still under investigation. One idea is: Generate a GUI for PDT's on PC using COTS DBMS package and transfer to DAPS in correct DG format	Provide a user friendly GUI in new or re-hosted DAPS.
DAPS Software Maintenance Support	Need additional software support for Wallops	Hire government software engineer or contractor to support Wallops software upgrades	Maintenance support services from contractor implementing new or re-hosted DAPS

## ***PRELIMINARY***

**Table 3-1 DCS Problems and Possible Solutions**

<b><u>Problem</u></b>	<b><u>Description</u></b>	<b><u>Short Term Solutions</u></b>	<b><u>Long Term Solutions</u></b>
DCS Firewall	Need firewall for new Internet and FTP access to DCS	Design and implement a DCS firewall	Make sure firewall is implemented on new or re-hosted DAPS
Data General replacement boards	Wallops cannot repair DG boards on site and must obtain replacement boards from 3 <sup>rd</sup> party vendors	Procure boards which are available from 3 <sup>rd</sup> party vendors for up to 5 years	New or re-hosted DAPS
Test Transmit antenna amplifiers	Lightning striking fence causes amplifier failures. Problem occurring since fence has been grounded	Determine if antennas have been grounded.	TBD
Wallops backup	Single point of failure at Wallops in event of catastrophic failure	Still under investigation Consider DCS as part of Wallops backup	Include backup to Wallops in new or re-hosted DAPS
Tenths of seconds	No evolutionary path in current system to allow fractional seconds for users	Still under investigation	TBD

# PRELIMINARY

## Appendix A

### DCS Cost Summary

Table A-1 itemizes the total \$7.5 million purchase price of the DCS. It includes the hardware costs and the DAPS software development costs. This information was provided by OSD-3 and is based on the actual invoices, whenever possible.

**Table A-1 DCS Purchase Costs**

Category	Cost in \$s	Comments
RF & Antenna Equipment	3.3 Million	1.8 million \$s for GOES Antenna's assuming 20% of the antenna is dedicated to DCS function 780 k \$s for DICE 500 k \$s for Demodulation equipment
Computer Equipment	1.1 Million	1 million \$s for DG MV20000 Eclipse computer equipment
Software Development	3.0 Million	DAPS software design, development and testing
Recent Upgrades	75 k	DG Y2K upgrades, Internet server, TCP/IP, and Firewall

Table A-2 summarizes the \$1 million yearly personnel costs to manage and operate the GOES DCS. Costs were calculated based on an estimate of the GS salaries of all current DCS personnel and adding a 30% overhead factor to these salaries.

**Table A-2 Current Yearly Operations & Maintenance Costs (in \$1000's)**

Organization	Management	Engineering	Operations
OSO	25	80	550
OSDPD	150	40	90
OSD	20	25	n/a

Table A-3 contains a listing of equipment dedicated at least partially to the DCS operations. Some items are shared with other functions, such as the GOES main antenna and receive system. An allocation of usage DCS was estimated based on the number of services sharing the equipment.

# PRELIMINARY

## Appendix A

### Table A-3 DCS Equipment List

<b>RF side</b>	<b>Manufacturer</b>	<b>Model No.</b>	<b>Quantity</b>	<b>Comment</b>
Demods	Vitel	GR3120	44	
Demod chassis	Vitel	GR3130	5	
Demod test set	Vitel	none	1	
Demods	Telcom	none	136	
Demod chassis	Telcom	none	14	
Helix antenna cntrl		GO153/4	3	
DICE equipment			3	
DICE test set			1	
DICE antenna control unit			1	
DICE failover switch unit			1	
Demod test eq.	Telcom		1	
RF patch panel			4	
Test transmitter	Dynatech		1	
Local area data xmtr	Avanti		2	
<b>RF Test equipment</b>	<b>Manufacturer</b>	<b>Model No.</b>	<b>Quantity</b>	<b>Comment</b>
Differential voltmeter	Fluke	86907	1	
Data error analyzer	HP	1645A	1	
Timing reference	Systron Donner	8181	1	
Digitizing oscilloscope	Tektronix	TDS420A	1	
Spectrum Analyzer	HP	8563A	1	
Frequency synthesizer	Fluke	15518	1	
High rate demod	Sutron		1	For development testing
High rate demod PS	Sutron		1	For development testing
<b>DAPS side</b>	<b>Manufacturer</b>	<b>Model No.</b>	<b>Quantity</b>	<b>Comment</b>
MV20000 Eclipse	Data General	MV20000	3	Spare used for board storage
9 track tape drive	Data General		3	Used for archiving
2.1 GB disk drives	Seagate		8	Local & global disks
Disk drive chassis	Envisage		4	Local & global disks
Power supply	Lambda		1	Local & global disks power supply
Modems	Universal Data Sys.	V.3225	5	19200 KB Dial-in lines
Modems	Universal Data Sys.	V.3400	5	19200 KB Dial-in lines
Modems	Universal Data Sys.		2	9600 KB Internet test connection
Fallback switch panel	ARC		2	Failover switch assembly
Power supply	ARC		2	Failover switch power supply
Monitor terminal	Teleray		3	DAPS local console
Time code generator	Datum	9100	2	
Commander 4/8	Itron	Mux	1	Connection to remote manager
Data Quality Monitor		386 PC	1	Custom ISI rack mounted PC
<b>DAPS Test Equipment</b>	<b>Manufacturer</b>	<b>Model No.</b>	<b>Quantity</b>	<b>Comment</b>
Logic analyzer	Digilog	620	1	
MicroVAX	DEC	MVII	2	Internet server test connection
Disk drives	Motorola	Codes	4	Split system testing
Monitor terminal		Pentium PC	1	Split system testing
A/B switch			1	Split system testing